

People deserve fiber.

genexis 



Pure E600 Installation Guide

Revision 2.0 - October 2023 - Copyright © 2023 Genexis Netherlands B.V. All rights reserved.

Multiple languages of this document and additional product information are available on <https://genexis.eu/product/pure/downloads>

Genexis assumes no responsibility for any inaccuracies in this document. Genexis reserves the right to change, modify, transfer, or otherwise revise this publication without notice.

Wi-Fi EasyMesh™ supported

Installation with use of app

You're just a few steps away to install your device via the Genexis EasyWiFi app

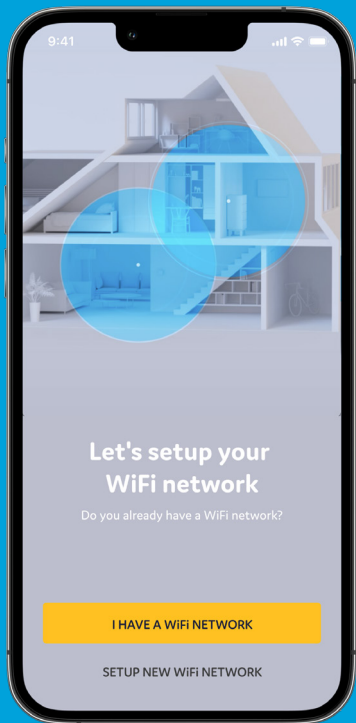

1

Scan QR-code



2

Download app and follow the steps



Installation guide

Getting started

Check if the following items are in the giftbox:

- Genexis Pure E600
- Power adapter
- Network cable
- Labels (self-adhesive)
- Rubber feet (self-adhesive)
- Plugs & screws

Label position

The product label is positioned on the bottom of the Pure E600 device and additional labels are included in the giftbox.

Genexis EasyWiFi app

Installation and management of the Genexis Pure E600 device can be done with help of the mobile application Genexis EasyWiFi. Please follow the steps on the left page.

Warning: Do not cover the device with anything, or put the device horizontally on a flat surface, because this will interfere with the ventilation of the Pure E600.

Operation Temperature 0°C ~ 40°C

Placement

Pure E600 supports two placement options; standing (desktop) and wall-mounted. It is recommended to place the device 'away' from obstacles and objects.

Standing

1. Place the device on a flat surface using the stand.
2. The rubber feet need to be attached to the stand accessory for stable placement.

Wall-mount

1. Download and print the drilling guide from <https://genexis.eu/product/pure/downloads>
2. Use the drilling guide to drill the holes, insert plugs and put screws into place.
3. Remove the stand from the device by sliding it towards the front.
4. Store the stand in a safe place.
5. Use the wall mount points on the back of the Pure E600 to mount the device to the screws.

Setting up the Pure

1. Connect a network cable between your broadband outlet and the Pure E600 WAN port (red connector).
2. Connect the supplied power adapter to the Pure E600 and plug the adapter into a power socket.
3. Flip the ON/OFF switch at the back of the device to turn it on.
4. Wait until Status, Uplink and Internet LEDs turns solid green.

Your Pure E600 is now ready for use.

Connecting your telephone

You can connect two regular plain telephones to the Pure E600.

1. Insert a telephone cable of a regular wired telephone in one of the telephone ports (green connectors).

Switching the WiFi ON/OFF

The WiFi function of the Pure E600 can be switched ON or OFF by means of the Mode button.

- Switch OFF: On the Pure E600, press and hold the Mode button until the WiFi LED turns off.
- Switch ON: On the Pure E600, press and hold the Mode button until the WiFi LED turns on.

Connecting to the wireless network

Automated pairing

You can connect your personal device to the Pure E600 by scanning the QR-code on the label of the Pure E600 or use the Mode button (WPS function) of the Pure E600. Please check on your personal device how this can be initiated. Before pairing, make sure the WiFi LED is solid green. If not, switch the WiFi ON as described in this installation guide.

Manual pairing

You can connect your personal device to the Pure E600 via manual pairing using the WiFi network name and WiFi key printed on the label of the Pure E600.

1. Perform a search of available wireless networks on your personal device.
2. Select the WiFi network name printed on the label.
3. Enter the WiFi key printed on the label.

Using the web interface

When connected to your network, you can access the Pure E600 web interface to change your device settings.

1. Use a web browser on your personal device and navigate to 'GUI' as printed on the label of the Pure E600.
2. Login by inserting the 'Username' and 'Password'.
3. If required, change your device configuration.

LED & button overview

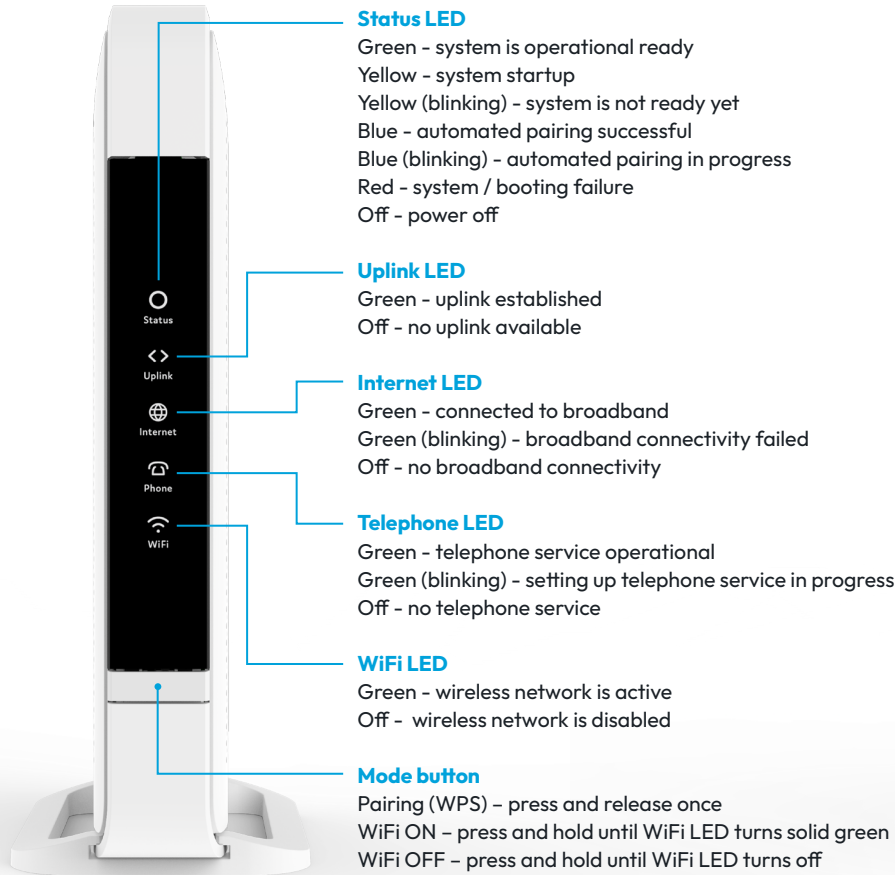

Port overview

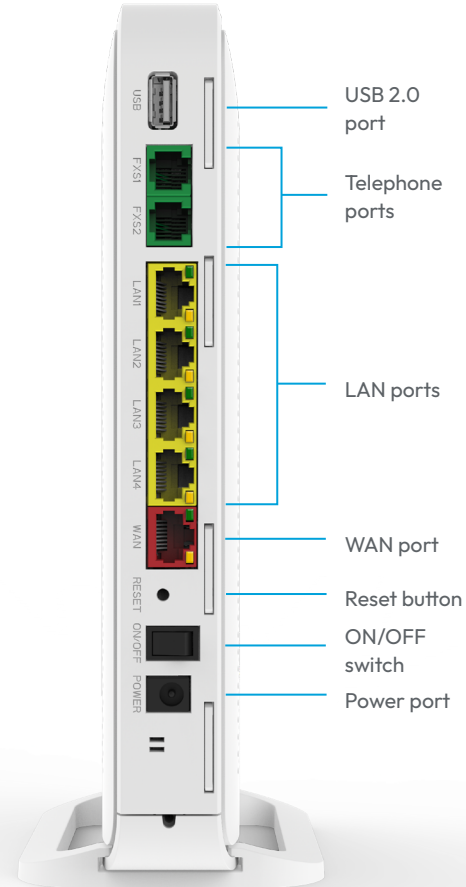

Reset button (recessed)

Reboot - press and release once
Factory reset - press and hold until all LEDs start fast blinking green

ON/OFF switch

Switch ON - flip the switch to ON
Switch OFF - flip the switch to OFF

Support

Is the Status LED solid red?

Contact your service provider.

Is the Status LED not solid blue after automated pairing?

Automated pairing between the Pure E600 and your personal device failed. Please follow the instructions again to connect your personal device to the wireless network.

Is the Status LED blinking yellow?

The Pure E600 is being upgraded with new software. Please wait until the status LED turns solid green again.

Is the Uplink LED off?

Pure E600 does not have a connection with the broadband network. Please verify your wired connection with the broadband outlet or contact your service provider.

Is the Internet LED off for 5 minutes?

Pure E600 does not have an internet connection. Please contact your service provider.

Is the WiFi LED off?

The WiFi of the Pure E600 is turned OFF. Please turn the WiFi ON as described in this installation guide.

Return the Pure E600 to factory default settings

With the reset button you can reset the Pure E600 to its factory default settings. You can press this button with a small pin or paperclip.

1. Press and hold the reset button until all LED's start fast blinking green.
2. Wait until the Status LED turns solid green again.

Your Pure E600 is now setup again with factory default settings as printed on the label.

EU Declaration of Conformity

Hereby, Genexis Netherlands B.V. declares that the radio equipment type Pure E600 is in compliance with Directive 2014/53/EU, Directive 2009/125/EC, Directive 2011/65/EU and Delegated Directive 2015/863.

The full text of the EU declaration of conformity is available at the following internet address: <https://genexis.eu/product/pure/red/pure-e600>

Company Name

Genexis Netherlands B.V.

Company Address

Lodewijkstraat 1a
5652 AC Eindhoven
The Netherlands

Signature of authorized person



Name and title of authorized person

Maarten Egmond, CTO

Place of issue

Eindhoven
The Netherlands

Date of issue

2021-06-21

Frequency bands and maximum radio frequency power transmitted

The Pure E600 operates in the frequency bands of 2,4 Ghz and 5Ghz.

The maximum radio frequency power transmitted in these bands is:

20 dBm (100 mW) (EIRP) for the 2400 MHz – 2483.5 MHz band

23 dBm (200 mW) (EIRP) for the 5150 MHz – 5350 MHz band *

30 dBm (1000 mW) (EIRP) for the 5470 MHz – 5725 MHz band

* In EU, 5150 – 5350 MHz is restricted to indoor.